



Instructions for the safe use of Flints Bar Divertors

**The information in this leaflet should be passed to
the user of the equipment**

This document is issued in accordance with the requirements of Section 6 of the Health and Safety at Work Act 1974, amended March 1988.

These instructions apply to Flints Bar Divertors for Hanging Clamps with Codes BARSW93BK, FHS002S and FHS002SL

Working Load Limit 550kg

Use for which the article is designed

Flints Bar Divertors have been designed for the flying of conventional steel or aluminium flying bars in the indoor theatre environment. They are designed to allow flying wires to be diverted along the flying bar to allow maximum flying travel. They should be fitted directly to Flints Hanging Clamps types FHS002HC and FHS002LHC. Diverting wires along a bar increases the loads imposed on the fittings and bar. Refer to Safe Use Section on this sheet. It is assumed the flying bars are flown using standard theatre counterweight or hemp systems or power flying systems fitted with soft starts. The use of the fittings for any other purpose would be inappropriate. The fittings should be fitted to the tube by a competent person familiar with the theatre environment.

Always

- ✓ Store the fittings in a area which is dry, clean and protected from corrosion.
- ✓ Inspect the fittings before putting into use or before being placed into storage. Any fittings found to be faulty should be marked as such and taken out of service and destroyed.
- ✓ Ensure fittings are selected and fitted by a competent person.
- ✓ Ensure the fittings are used in such a way that the failure of any one fitting would not lead to a dangerous situation.
- ✓ Ensure any fitting subjected to excessive load by way of shock loading or any other means is immediately removed from service and marked for destruction.
- ✓ Follow the fitting instructions.
- ✓ Ensure the load is applied in the direction as stated in the instructions.
- ✓ Ensure the fittings are thoroughly inspected by a competent person at six monthly intervals or after any exceptional circumstance or according to an examination scheme.
- ✓ Individually mark the fittings and record their details together with the EC Declaration of Incorporation.

Never

- ✗ Never exceed the working load limit.
- ✗ Subject fittings to shock loads.
- ✗ Never use a divertor which has a bent bolt, or has been modified in an unapproved manner, stretched, has nicks, gouges or cracks, has signs of heat or burning, or signs of corrosion.
- ✗ Apply a load without ensuring the wire is correctly seated in the sheave groove.

Selection of Correct Fitting

Choose the Bar Divertor according to the diameter of the wire being used. Use BARSW93BK for 5mm wire, use FHS002S for 6mm wire and use FHS002SL for 8mm wire. Wires should be of a flexible construction.

Correct Fitting All types of Bar Divertors should be attached to the top 13mm diameter hole provided in Flints Hanging Clamps

using the Grade 8.8 hexagonal M12 bolt, washers and Nylon insert nut provided. Tighten the Nylon insert nut until some thread from the bolt protrudes from end of the nut but do not tighten hard down so the sheave can still rotate slightly when subjected to a load.

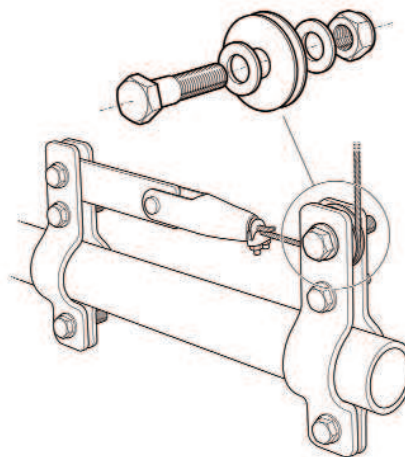

Safe Use

Deflecting a wire by 90° will increase the load on the fitting by

141%. The vertical Working Load Limit of the Hanging Clamp and of the Bar Divertor is 550kgs so the force exerted on the wire when diverted 90° should not exceed 390kg. The load should be applied so that the wedge socket is able to articulate in the direction of the wire. Bridles should not be employed when using Bar Divertors without consulting a competent person with a knowledge of the Trigonometric Method of rating slings. Before applying a load ensure the wires are correctly seated in the sheave groove. Care should be taken during flying to avoid shock loads which may arise due to wires becoming slack if a piece of scenery becomes caught on a fixed object while flying in.

In Service Inspection and Maintenance The fittings should be kept clean and free of corrosion. They must be inspected every six months or after any exceptional circumstance or according to an examination scheme drawn up by a competent person. Check the Nylok nut is secure and the sheave can rotate. Inspect for illegible markings, distortion, wear, stretched or bent bolts, nicks, gouges, cracks, corrosion, heat marks or any other defect. If in doubt replace the fitting or seek further advice.

© Copyright Flint Hire & Supply Ltd. February 2010



FS 539611

flints.co.uk
FLINTS
Theatrical Chandlers