

# PREFERRED LOCATION FOR STAMPED MARKINGS IN CROSBY HARDWARE

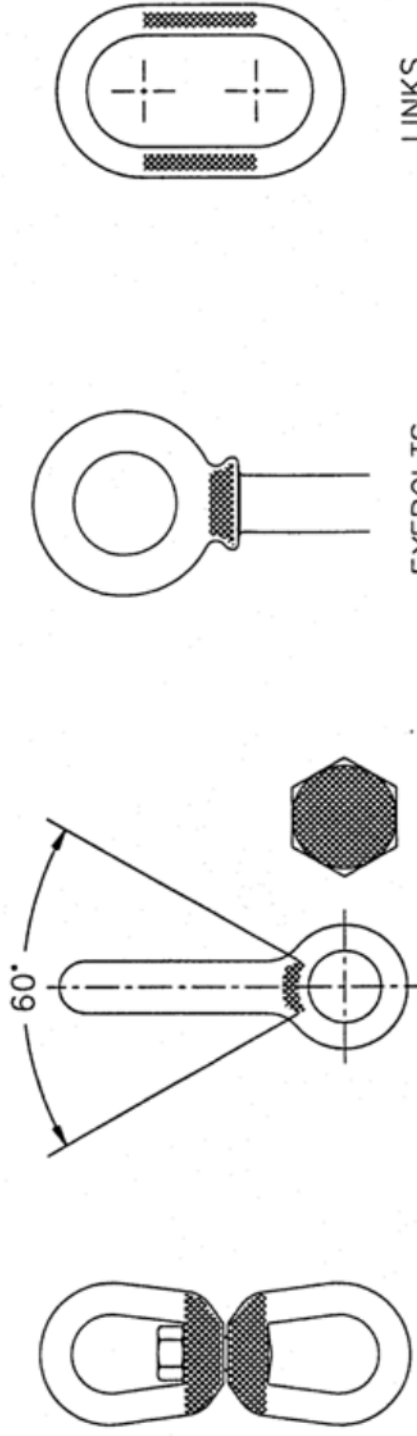

FORGED SWIVELS

SHACKLES

EYEBOLTS

LINKS

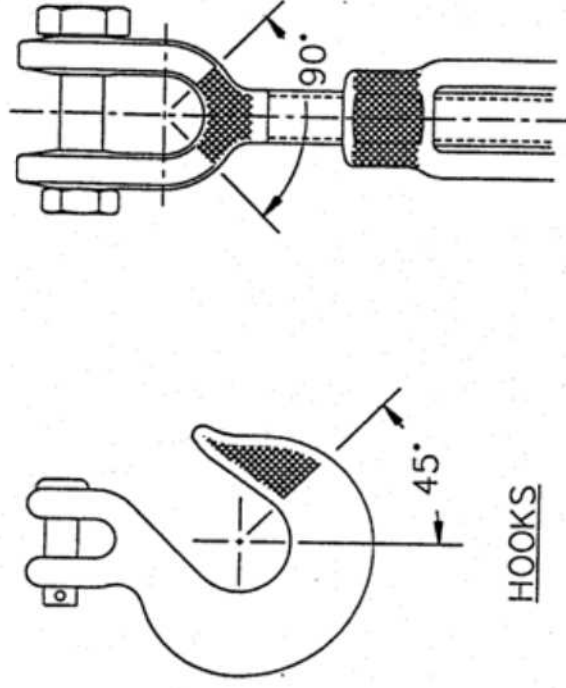

HOOKS

TURNBUCKLES

Copyright © 2005 The Crosby Group, Inc.  
All Rights Reserved

**n.v. Crosby** europe

(POH548A)

Copyright © 2008 The Crosby Group, Inc.  
All Rights Reserved

MODULE SLIDE 7-14

# STAMPED MARKINGS IN CROSBY MASTER LINKS AND SHACKLES

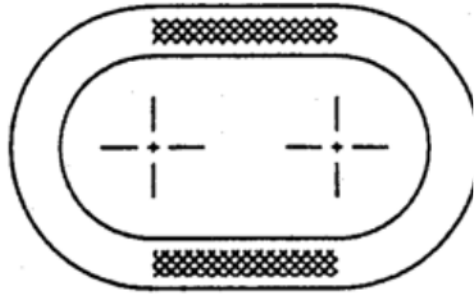

## MASTERLINK

1. USE LOW STRESS OR DOT FACED STAMPS OF APPROPRIATE SIZE ON INDICATED AREAS
2. INDENTATION NO DEEPER THAN 0.5 mm
3. DO NOT STAMP FITTING LESS THAN 13 mm NOMINAL SIZE

## SHACKLE

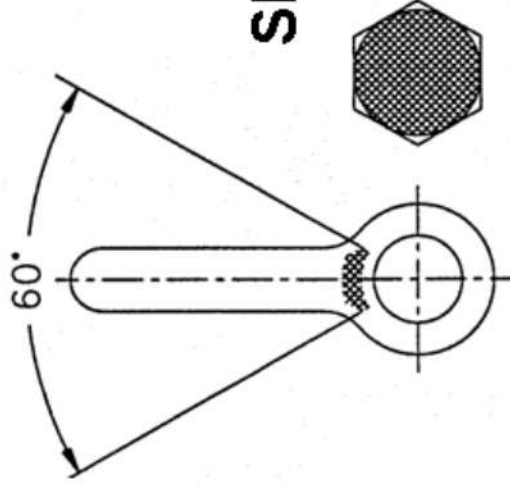

4. VIBRA- ETCH TOOL MAY BE USED ON ALL SURFACES
5. SPECIFY STAMPS AS:  
ROUND FACE - FULL CHARACTER  
OR ROUND FACE - DOT DESIGN

(POH548D-E)

Copyright © 2008 The Crosby Group, Inc.  
All Rights Reserved

**n.v. Crosby** europe

MODULE SLIDE 7-15

# CROSBY STAMPING INSTRUCTIONS

USE LOW STRESS OR DOT FACED STAMPS OF  
APPROPRIATE SIZE ON INDICATED AREAS

INDENTATION NO DEEPER THAN .5 mm

DO NOT STAMP FITTING LESS THAN 13 mm NOMINAL  
SIZE

VIBRA- ETCH TOOL MAY BE USED ON ALL SURFACES

SPECIFY STAMPS AS: ROUND FACE - FULL  
CHARACTER OR ROUND FACE - DOT DESIGN

(POH548B)

Copyright © 2008 The Crosby Group, Inc.  
All Rights Reserved

**n.v. Crosby** europe

MODULE SLIDE 7-16